

| | |
|--|--------------------------------------|
| MATERIAL: | 1035 STEEL OR BETTER |
| HARDNESS: | 38-45HRC THROUGH HARDENED |
| MECH. & PHYSICAL PROPERTIES | PER ASTM F-436 |
| HEADMARK: | "NT2" & DIAMETER + "S" (SEE DIAGRAM) |
| FINISH: | ZINC YELLOW CR+6 |

PRODUCT IS NOT DRAWN TO SCALE

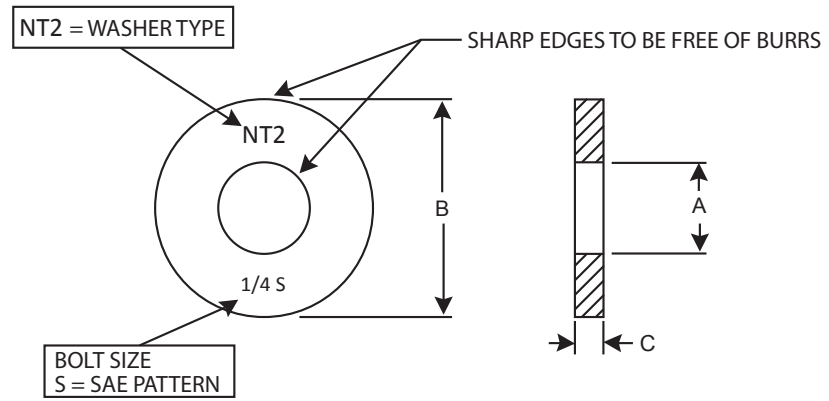

| Nom Bolt Size | Part Number | A | | | B | | | C | |
|---------------|-------------|------------|-------|-------|-------------|-------|-------|-----------|-------|
| | | Inside Dia | | | Outside Dia | | | Thickness | |
| | | Basic | +TOL | -TOL | Basic | +TOL | -TOL | Max | Min |
| 1/4 | 25SNT28Y | 0.281 | 0.015 | 0.005 | 0.625 | 0.015 | 0.005 | 0.080 | 0.064 |
| 5/16 | 31SNT28Y | 0.344 | 0.015 | 0.005 | 0.688 | 0.015 | 0.007 | 0.093 | 0.079 |
| 3/8 | 37SNT28Y | 0.406 | 0.015 | 0.005 | 0.812 | 0.015 | 0.007 | 0.093 | 0.079 |
| 7/16 | 43SNT28Y | 0.469 | 0.015 | 0.005 | 0.921 | 0.015 | 0.007 | 0.106 | 0.090 |
| 1/2 | 50SNT28Y | 0.531 | 0.015 | 0.005 | 1.062 | 0.030 | 0.007 | 0.146 | 0.122 |
| 9/16 | 56SNT28Y | 0.594 | 0.015 | 0.005 | 1.156 | 0.030 | 0.007 | 0.146 | 0.122 |
| 5/8 | 62SNT28Y | 0.656 | 0.030 | 0.007 | 1.312 | 0.030 | 0.007 | 0.160 | 0.136 |
| 3/4 | 75SNT28Y | 0.812 | 0.030 | 0.007 | 1.469 | 0.030 | 0.007 | 0.160 | 0.136 |
| 7/8 | 87SNT28Y | 0.938 | 0.030 | 0.007 | 1.750 | 0.030 | 0.007 | 0.160 | 0.136 |
| 1 | 100SNT28Y | 1.062 | 0.030 | 0.007 | 2.000 | 0.030 | 0.007 | 0.160 | 0.136 |

DESCRIPTION:
SAE PATTERN "NT2" THICK HARDENED FLAT WASHERS

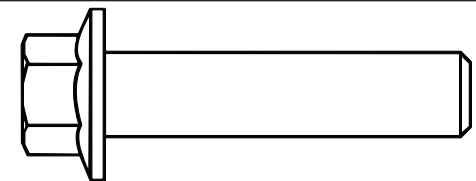

EARNEST MACHINE CLAIMS ALL PROPRIETARY RIGHTS TO THIS DRAWING AND THE INFORMATION IT CONTAINS. THIS MATERIAL IS CONFIDENTIAL. DISCLOSURE, REPRODUCTION, AND MANUFACTURING IS STRICTLY PROHIBITED WITHOUT THE EXPRESS WRITTEN PERMISSION OF EARNEST MACHINE ALL RIGHTS OF DESIGN OR INVENTION ARE RESERVED.

THIS DRAWING IS FOR REFERENCE ONLY AND SHOULD NOT BE USED DURING THE MANUFACTURING PROCESS.

UNITS: INCH

PRODUCT SERIES: SNT28Y

DATE: 1/9/15

REV: A