

MATERIAL:	LOW CARBON STEEL
HEADMARK:	NO MARKING REQUIRED
FINISH:	ZINC CLEAR CR+3

PRODUCT IS NOT DRAWN TO SCALE

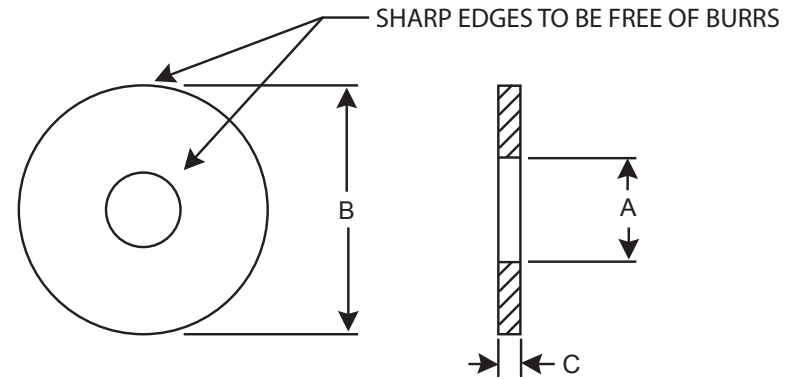

Nom Bolt Size	Part Number	A			B			C	
		Inside Dia			Outside Dia			Thickness	
		Basic	+TOL	-TOL	Basic	+TOL	-TOL	Max	Min
3/16	10X100XFW2Z	0.219	0.015	0.005	1.000	0.015	0.005	0.132	0.108
1/4	25X100XFW2Z	0.281	0.015	0.005	1.000	0.015	0.005	0.132	0.108
1/4	25X125XFW2Z	0.281	0.015	0.005	1.250	0.015	0.005	0.132	0.108
1/4	25X150XFW2Z	0.281	0.015	0.005	1.500	0.015	0.005	0.132	0.108
5/16	31X125XFW2Z	0.343	0.015	0.005	1.250	0.015	0.007	0.132	0.108
5/16	31X150XFW2Z	0.343	0.015	0.005	1.500	0.015	0.007	0.132	0.108
3/8	37X125XFW2Z	0.406	0.015	0.005	1.250	0.015	0.007	0.132	0.108
3/8	37X150XFW2Z	0.406	0.015	0.005	1.500	0.015	0.007	0.132	0.108
3/8	37X200XFW2Z	0.406	0.015	0.005	2.000	0.015	0.007	0.132	0.108
1/2	50X200XFW2Z	0.531	0.015	0.005	2.000	0.015	0.007	0.132	0.108

DESCRIPTION:
1/8" EXTRA THICK FENDER WASHERS

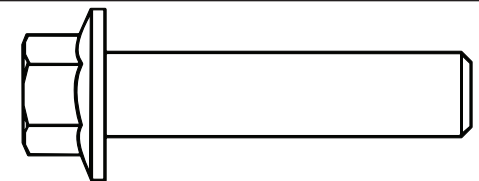

EARNEST MACHINE CLAIMS ALL PROPRIETARY RIGHTS TO THIS DRAWING AND THE INFORMATION IT CONTAINS. THIS MATERIAL IS CONFIDENTIAL. DISCLOSURE, REPRODUCTION, AND MANUFACTURING IS STRICTLY PROHIBITED WITHOUT THE EXPRESS WRITTEN PERMISSION OF EARNEST MACHINE. ALL RIGHTS OF DESIGN OR INVENTION ARE RESERVED.

THIS DRAWING IS FOR REFERENCE ONLY AND SHOULD NOT BE USED DURING THE MANUFACTURING PROCESS.

UNITS: INCH

PRODUCT SERIES: XFW2Z

DRAWN: AGRAHAM

DATE: 1/9/15

REV: A